

# FICHA TÉCNICA PREMIUM 2x6

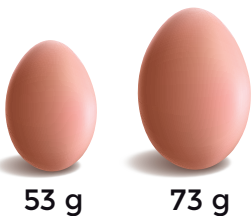

**UNIDADES:** 2  
**HUEVOS/UNIDAD:** 6  
**MATERIAL:** R-PET + PET  
**MODELO:** Premium 2x6  
**PESO ENVASE:** 37 g  
**CALIBRE:**



## ALMACENAMIENTO

Almacenamiento máximo 1 año



Máx. 38°C / 100°F  
Min. 5°C / 41°F



No exponer al sol

## CARGA DE CONTENEDOR



20"	79.696 Cartons
40" HC	187.523 Cartons

## DIMENSIONES DE LA CAJA



Interior: 911x311x452 mm (LxAxH)  
Exterior: 920x315x456 mm(LxAxH)

Peso neto	12,38 kg
Peso de la caja	1,3 kg
Peso bruto	13,68 kg
Envases/Caja	344

## DECORACIÓN



Espacio para etiqueta



# FICHA TÉCNICA PREMIUM 2x6

## DIMENSIONES DEL ENVASE

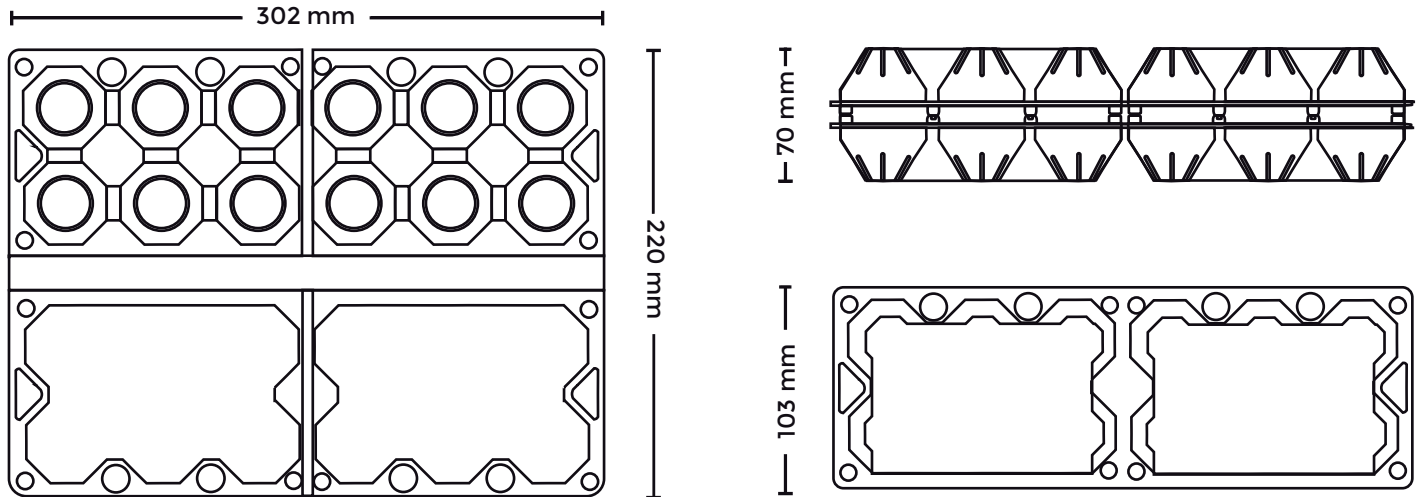

\* Medidas expresadas en milímetros  
Tolerancia  $\pm 0,5$  mm

## RESISTENCIA

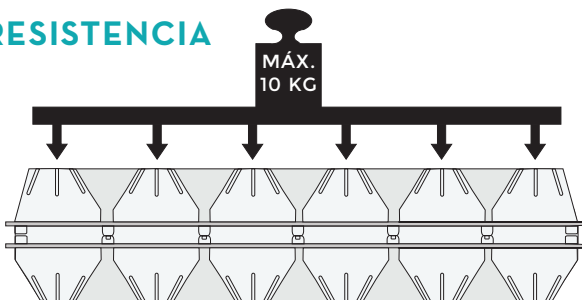

Peso máximo uniformemente distribuido sobre la superficie superior.

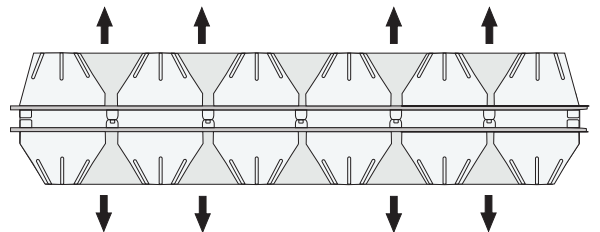

Fuerza de apertura superior a 1,7 kg aplicada directamente sobre el sistema de cierre