

FICHA TÉCNICA EXCELL 1x12

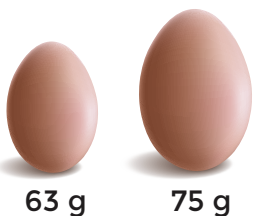

UNIDADES: 1
HUEVOS/UNIDAD: 12
MATERIAL: R-PET + PET
MODELO: Excell 1x12
PESO ENVASE: 37g
CALIBRE:



ALMACENAMIENTO
 Almacenamiento máximo 1 año



Max. 38°C / 100°F
 Min. 5°C / 41°F



No exponer al sol



CARGA DE CONTENEDOR

20" 77.380 Envases
 40" HC 212.590 Envases



DIMENSIONES DE LA CAJA

Interior: 911x311x452 mm (LxAxH)
 Exterior: 920x315x456 mm (LxAxH)

Peso neto 14,04 kg
 Peso de la caja 1,3 kg
 Peso bruto 15,34 kg
 Envases/Caja 390



DECORACIÓN

Espacio para etiqueta



FICHA TÉCNICA

EXCELL

1x12

DIMENSIONES DEL ENVASE

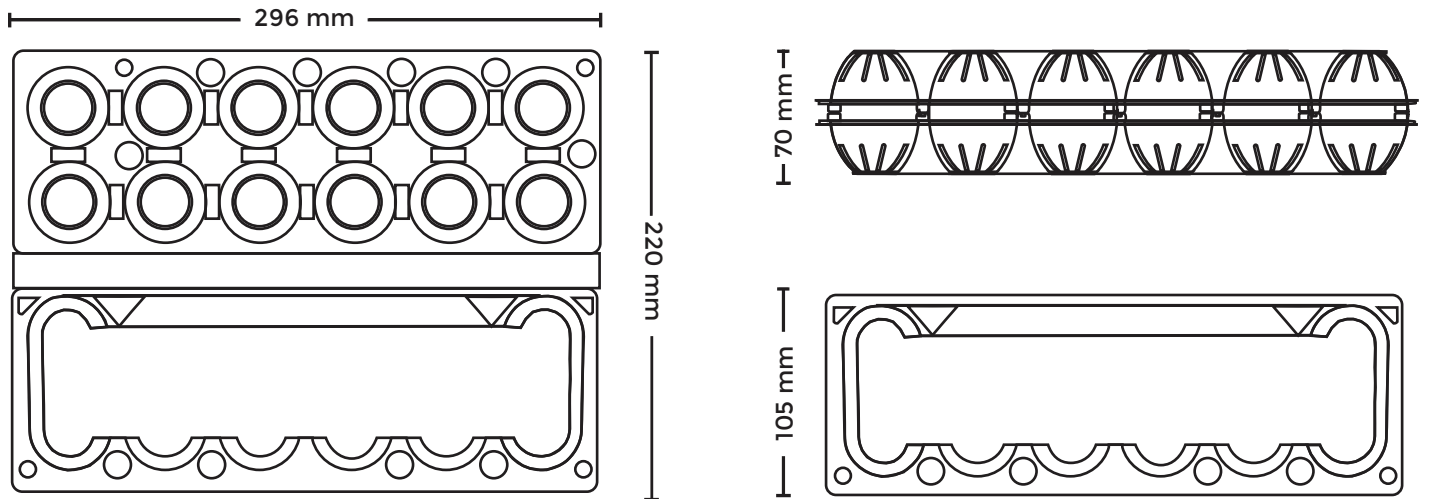

* Medidas expresadas en milímetros
Tolerancia $\pm 0,5$ mm

RESISTENCIA

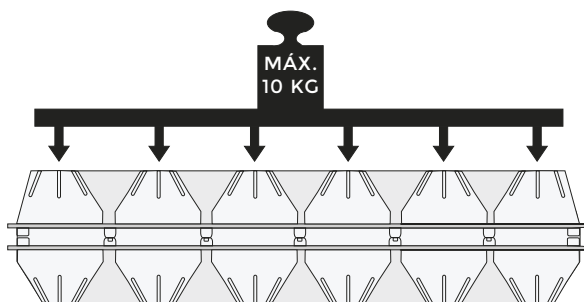

Peso máximo uniformemente distribuido sobre la superficie superior.

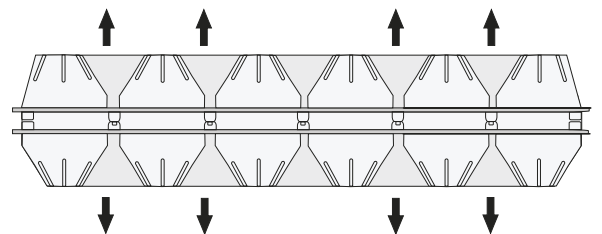

Fuerza de apertura superior a 1,7 kg aplicada directamente sobre el sistema de cierre